

Muuntoyhde

RCLUSS



Tuotekuvaus

Pitkä palaosista rakennettu keskeismuuntoyhde n.18 ° kulmalla.

Tuote on CE-merkitty EN 12101-7 standardin mukaisesti käytettäväksi pyöreissä savunhallintakanavajärjestelmissä.

Mitat

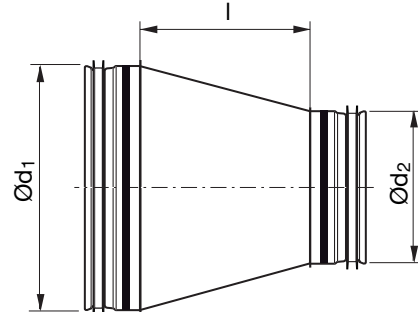

Ød ₁ nom	Ød ₂ nom	l mm	m kg
125	63	115	0,28
160	63	163	0,43
160	80	140	0,42
160	100	112	0,40
160	125	78	0,36
160	150	44	0,3
200	80	195	0,61
200	100	167	0,59
200	125	133	0,55
200	160	85	0,50
250	100	236	0,94
250	125	202	0,90
250	160	154	0,87
250	200	99	0,75
315	125	291	1,36
315	160	243	1,31
315	200	188	1,21
315	250	119	1,09
400	160	365	2,44
400	200	310	2,31
400	250	241	2,2
400	315	152	1,86
450	200	378	2,99
450	315	221	2,50
450	400	109	2,64
500	200	447	3,66
500	250	378	3,51
500	315	289	3,16
500	400	177	2,69
630	250	557	5,60
630	315	468	5,25
630	400	356	4,79

Tilausesimerkki

	RCLUSS	200	100
Tuotetunnus			
Koko Ød ₁			
Koko Ød ₂			

Muuntoyhde

RCLUSS

$\varnothing d_1$ nom	$\varnothing d_2$ nom	l mm	m kg
630	500	219	4
800	400	594	8,81
800	500	457	8,02
800	630	279	6,62
1000	500	732	13,1
1000	630	553	11,7
1000	800	325	9,91

1

2

3

4

5

6

7

8

9

10

11

12

13

14

15

16

17

18

Muuntoyhde

RCLUSS

Tekniset tiedot

1 dimensiojako

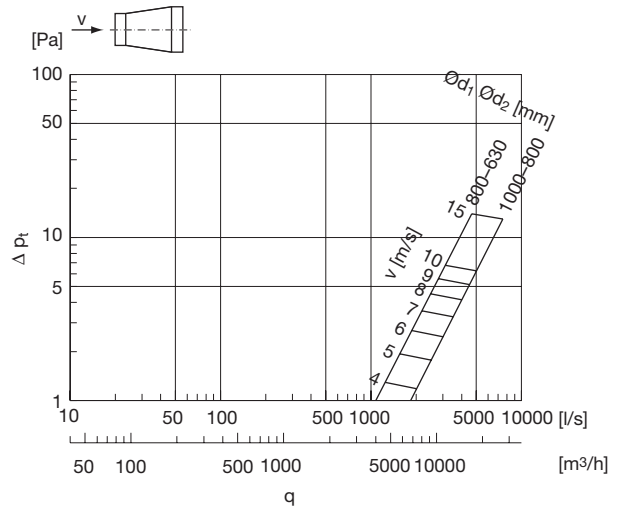
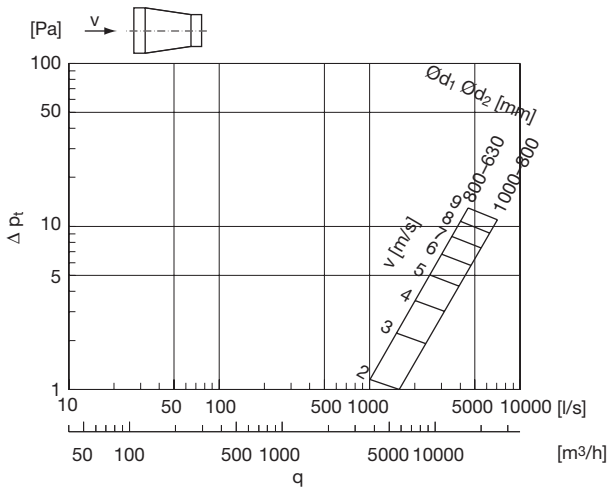

2 dimensiojaot

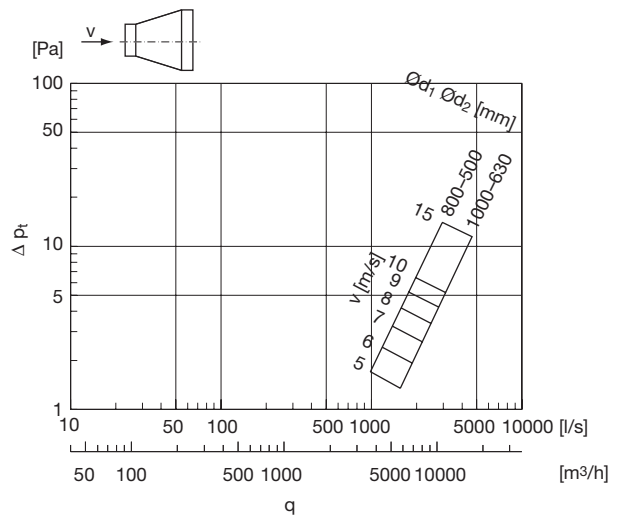
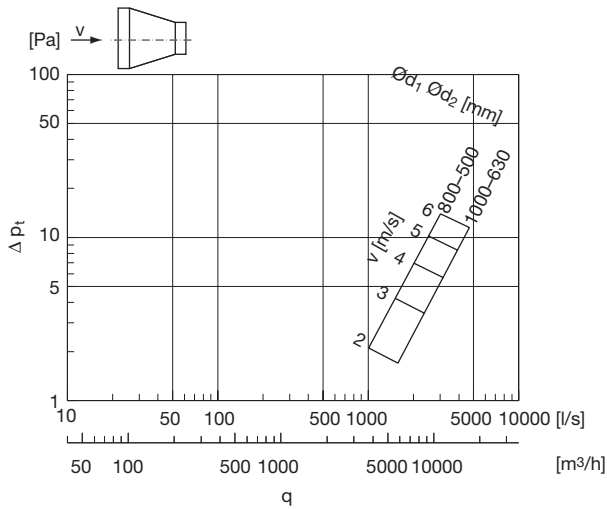

3 dimensiojaot

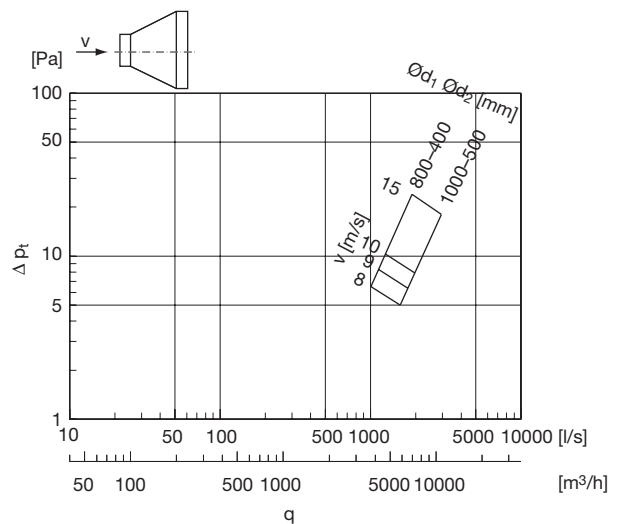
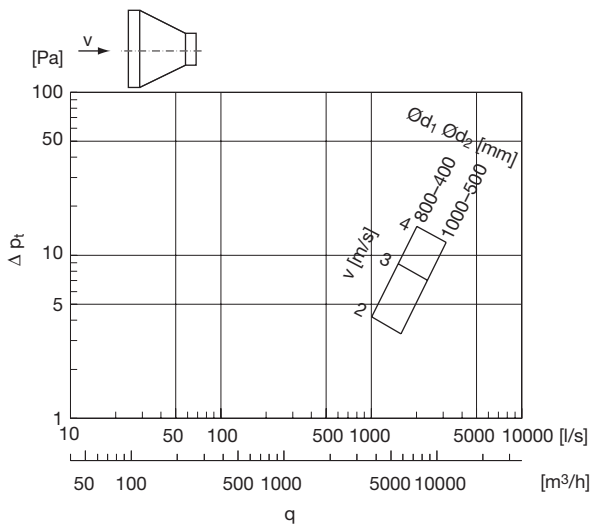

- 1
- 2
- 3
- 4
- 5
- 6
- 7
- 8
- 9
- 10
- 11
- 12
- 13
- 14
- 15
- 16
- 17
- 18